

## Tipi Program Setup Handout

Greater St. Louis Area Council  
Boy Scouts of America



**Rule # 1 - DO NOT DROP THE POLES**

**Rule # 2 - FOLLOW RULE # 1**

**Rule # 3 - NO FIRES inside the Tipi**

For the purpose of giving directions the Tipi will face east (direction of the door opening) as we give the following instructions.

To pitch the Tipi, select the three poles marked D, N, and S at butts, for the Door, North and South. Next select the three poles marked L and F and set them aside. These are the Lift and two Smoke Flap poles which will be used later.

In order to hoist the tripod into position, lay it on the ground at the time of tying, with the butts of two of the poles (labeled N & S) near the back of the circle marked "S" on the ground plan in figure 3c and the butt of the door (labeled D) at the point on the circle marked "D". Note that the door pole lays on top of the north and south poles and the dotted lines in figure 3c show the positions on the ground.

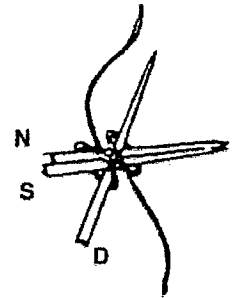

*Start with a clove hitch and finish with a few more turns and two half-hitches.*

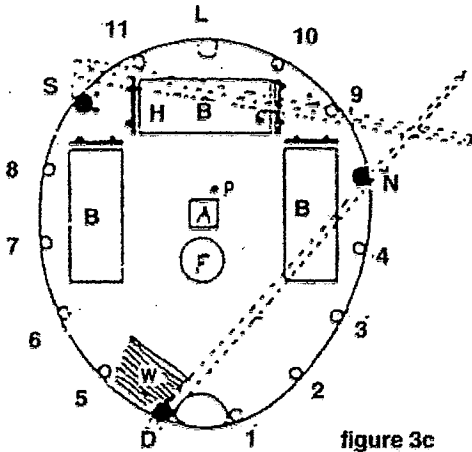

figure 3c

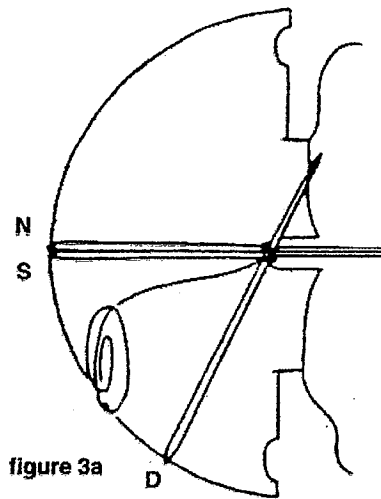
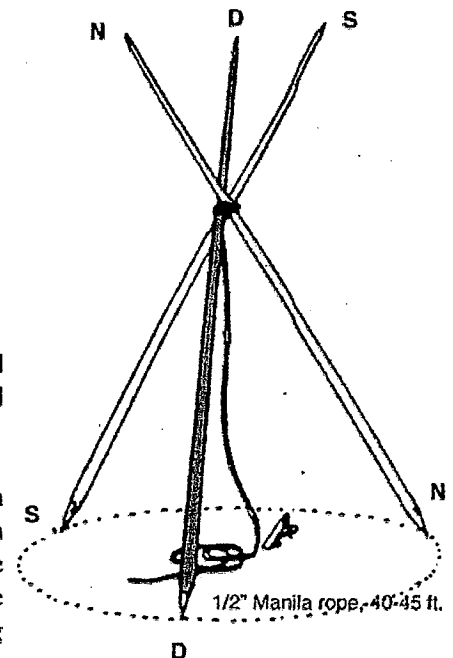

figure 3a

figure 3b



1/2" Manila rope, 40-45 ft.

Start by tying a "clove hitch" around the tripod poles with the 1/2" rope and leave about four feet of tail as shown in the detail drawing in figure 3a. Take the tail and wrap it four times around the tripod poles and finish with "two half-hitches".

Now get someone to hold the long end of this rope and hold it taut in a position outside of the circle between the south and door poles in figure 3c. Several others can then "foot" the north, south and door poles. Start by lifting the tripod poles near the tie point and walking up under them as they are raised. The person holding the rope should take up slack as the structure is raised. When the poles are almost erect swing the north pole (the right one of the pair) out towards the position marked "N" on circle in figure 3b. This "locks" the tripod into position so that it will not slip. Its final appearance should be checked with the drawing, for this is one of the most important steps in pitching the Tipi. Let the rope used to tie the tripod hang down in the center of the lodge as shown.

The tripod poles should be nearly positioned in their final position as possible at this time. In your training we had you step back and evaluate the tripod position. Do so at this time.

Now carry a pole and place it into position starting with and working consecutively with poles 1, 2, 3 and 4 and set them in the front crotch. Next set in poles 5, 6, 7 and 8 setting them also in the front crotch. This places 2/3 of the poles in the front crotch, which will produce the smallest bundle at the top. Now place poles 9, 10 and 11 into position and set them into the crotch formed in the back. Note the skipped space between poles 10 and 11. This is where the Lift Pole will go. Which will be discussed later. The poles should always be placed in this fashion. **This is not a random process!**

Poles 1 through 11 should be placed with their butts about 6-8 inches in from the circle. If not it will be impossible to stretch the cover around the structure. We will discuss their adjustment later.

Now take the rope which you used to tie the lodge poles together and walk between the South pole and pole number 8 and go around the outside of the structure four times. While doing so snap the rope upward and keep it taut. After the last pass go back to the center of the lodge between the North pole and pole number 4. Drive two large stakes into the ground at an angle about one foot apart and anchor the rope to these stakes. **This is a mandatory step.** This is the only thing which will hold the Tipi down in a high wind. I have personally seen a 70 mph wind take down a 24 foot Tipi which was not anchored correctly. **Please do not bypass this step, because your scouts safety is at stake.**

The cover should be rolled into a pie shaped bundle. Begin by taking a corner by the door and folding it back so that the edge with the lacing pins lies down the center and then again several more times. Repeat this on the other side. The outside of the cover should now be inside the bundle. Place the butt of the Lift pole into its final position and lay it on the ground at the back (see figure 3c for position). Place the cover along side the Lift pole and tie it at the place marked on the Lift pole. This is done by wrapping the tie tapes around the pole and finishing with a "bow knot".

Have someone foot the pole and then hoist the pole bundle and all up, just like you did when raising the tripod. Set the pole into place where pole 9, 10 and 11 were set by twisting the pole so that the cover is on the outside. The tie point should meet at the point where the poles are tied together. It is best to have help when doing this step. If this point is to high or to low or slips, remove the cover in reverse fashion, re-tie it and try again.

Now it is a simple matter of unrolling the cover from each side and carry it around the structure so that the door opening is just left of the Door pole. Pull the cover so that the lacing pins on the left overlap the ones on the right (south over north). The cover should be slack enough to do this easily. If not the poles (1-11) are out to far and should be moved towards the center a bit.

Insert the lacing pins starting at the top. Put the pin in through the hole on the top right and pass it through the one below. Now turn the pin to the right (north) and push it through the bottom left (south) and through the top. Repeat this process all the way down to the bottom of the door.

Insert the Smoke Flap poles labeled "F" but leave some slack until the cover is fully staked. This can be a challenge at night or in the wind or both. Make sure the tips of the poles are rounded so as not to put a hole in the canvas.

Begin staking down the Tipi by placing the first two on each side of the door. Then go to the back and start at the Lift pole and work both sides to the front. Use a "larks head" to fasten the tie down to the stake and twist it until the tie holds by itself. **Pound the stake straight down** until the cover is snug. Not to tight but firm so that it holds. **Unfortunately, some have driven the stakes all the way into the ground and have torn covers in the past. BE CAREFUL!!** (If your Tipi does not have sewn on loops you will need to install marbles. This is done by holding the marble under the inside edge of the cover, wrapping the canvas back over the marble to form a pocket. Then wrap a piece of thin cord around the canvas to hold the marble in the pocket. The other end of this cord is tied off to the stake. Leave the marbles and cord in place when taking down the Tipi, **DO NOT REMOVE THEM FROM THE CANVAS.**)

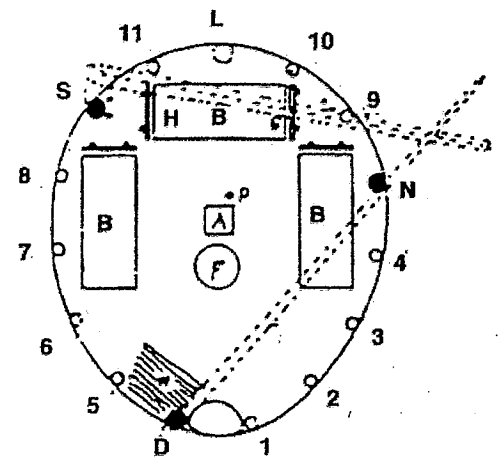

- |                |                       |
|----------------|-----------------------|
| A - Altar      | D - Door Pole         |
| B - Bed        | S - South Tripod Pole |
| F - Fire       | N - North Tripod Pole |
| P - Anchor Peg | L - Lift Pole         |
| W - Wood       | F - Front Crotch      |
| H - Host       | R - Rear Crotch       |
| G - Guest      |                       |

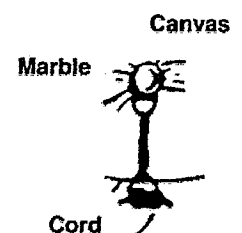
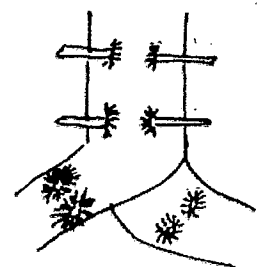

OK, now go back inside and push poles 1 through 11 out and down against the cover. You may need to twist the pole to get it to go. The North, South and Door poles should not be moved. In fact you will find it very difficult to do so should you attempt to. The Lift pole can be moved in or out in the event it is a bit too high or low or if a small wrinkle needs to be stretched. You can experiment with this if needed. Finally, stretch the smoke flaps tight by moving the poles up and forward.

The inside cover is optional, but you will find that without it the lodge is very uncomfortable, even in the summer.

Install the liner by tying the bottom rope first (the longer of the 1 1/4" line). For convenience start at the Door pole with a "clove hitch" and pass the rope in front and then behind the pole to your right (heading south). If the rope is passed behind and then in front of the pole the liner will be to close to the cover to perform its function. Continue around the lodge until you get to pole number one and finish with another "clove hitch". The height of the bottom rope varies between those at S-F versus Pine Ridge. At S-F tie it as close to the butt of the poles as possible due to the length of the liner, below the bottom tie tapes, referred to as the "sod cloth". At Pine Ridge they should be about 8-10 inches from the butt of the poles. The sod cloth should lay upon the ground to help seal out the elements.

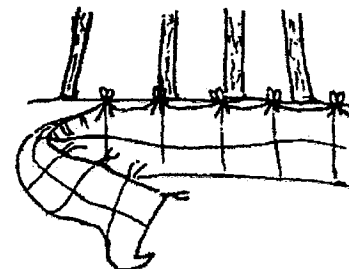

Unroll the inside liner so that the bottom tie tapes can be tied to this line. Without stepping on the canvas have someone sit down on the ground and begin tying the tie tapes. As this person progresses, two others can lift the top of the liner and determine where the top rope should be tied. You should tie at a point several inches above the top of the liner. Do so in the same manner as the bottom rope was tied. Typically this process takes three people to complete.

**ATTENTION:** To tie the tie tapes correctly and greatly help the take down process, you should tie the tapes using the following method.

Take the pair of tie tapes over the top of the rope, split them and bring them back to the front over the top of the tie tapes. Now, tie a bow without an overhand knot. With a little practice it will go quickly and you will appreciate your diligence when it is time to remove the liner.

Finally, install the door as shown in the small diagram on figure 3e. Stake out the Smoke Flap ropes or tie them to a 6-8 foot pole. You can place it about six feet out in front of the door. Do not tie them to a tree. Insert some "rain sticks" to the top of the liner rope where it is tied to the poles (this allows the rain drops that run down the poles to go down behind the liner. The liner carries the water on outside. The "rain sticks", which should be positioned toward the inside of the tipi pole keep the liner rope from intercepting these drops), and you are ready to move in and have fun.

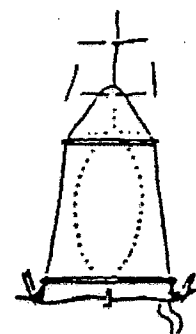
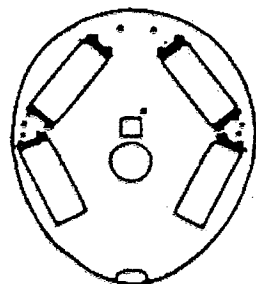
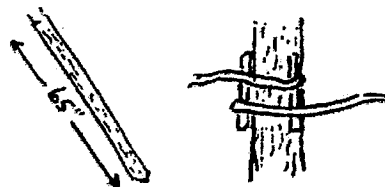

figure 3e

Door Cover



Another arrangement for sleeping.

**Tipi Camping Committee  
References Resources**

**BOOKS**

**The Indian Tipi**, Ballantine Books, by Reginald & Gladys Laubin (*A must for those wanting more information!*)  
**Frontiersman**, Venture Crew Book, BSA Bookstore  
**Indian Lore**, Merit Badge Book, BSA Bookstore  
**Craft Manual of North American Indian Footwear**, by George M. White  
**Primitive Outdoor Skills**, Horizon Publishers, by Richard L. Jamison  
**North American Indian Arts-A Golden Guide**, Dover Books  
**The Indian How Book**, Dover Books, by Arthur C. Parker  
**The Book of Buckskinning I**, Muzzleloader Magazine Rebel Publishing  
**The Book of Buckskinning II**, Muzzleloader Magazine Rebel Publishing  
**The Book of Buckskinning III**, Muzzleloader Magazine Rebel Publishing  
**The Book of Buckskinning IV**, Muzzleloader Magazine Rebel Publishing  
**The Book of Buckskinning V**, Muzzleloader Magazine Rebel Publishing  
**The Book of Buckskinning VI**, Muzzleloader Magazine Rebel Publishing  
**American Indian Survival Skills**, Outdoor Life Books, by W. Ben Hunt  
**The Mountain Man's Sketch Book**, The Fur Press, by James A. Hanson  
**Survival Skills of the North American Indians**, Chicago Review Press, by Peter Goodchild  
**Mystic Warriors of the Plains**, Double Day Press, by Thomas Moik  
**Mountain Crafts & Skills**, Horizon Publishers, by David Montgomery  
**The Complete How-To Book of Indian Crafts**, Collier Books, by W. Ben Hunt  
**Plains Indian, Dog Soldiers, Bear Men, Buffalo Women**, Promitory Press, by Thomas Moik  
**American Indian Craft Book**, Popular Library, by Minor  
**What-Cha-Ma-Call-Its**

**MAGAZINES**

Muzzleloader  
Muzzle Blasts  
The Back Woodsman

**RESOURCE LOCATIONS**

Tandy Leather Stores  
Arch Museum Bookstore  
Jefferson Barracks Museum Bookstore  
S-T Leather  
Dixie Gun Works, Union Tennessee  
Outdoor Life Book Club